

# 70 WATT

ATTRACTIVE LOOK. FLEXIBLE DESIGN.

## LEFT AND RIGHT TRIANGULAR PHOTOVOLTAIC MODULES WITH 70W MAXIMUM POWER

Sharp's new triangular photovoltaic modules offer the clean, pleasing look of a high-tech skylight while increasing design flexibility with balanced and attractive rooftop arrays. Engineered specifically for residential hip roofs and complex roof lines, these modules set a new standard in aesthetics.

The black anodized aluminum frames, trim strips, and backing sheets blend beautifully with the home's exterior. In addition, an "L" hook design located along the frame's perimeter ensures easy integration with the residential system mounting hardware. These modules also boast high conversion efficiency and are designed to withstand extreme heat and wind. Sharp's ND-070ERU/LU triangular residential system modules—an ideal combination of form and function from the global leader in solar technology.

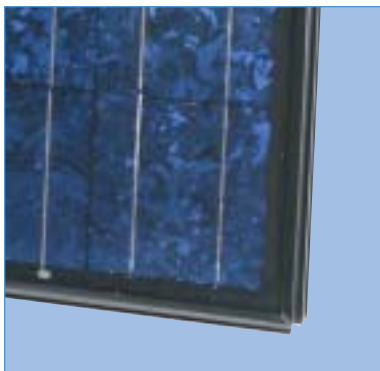
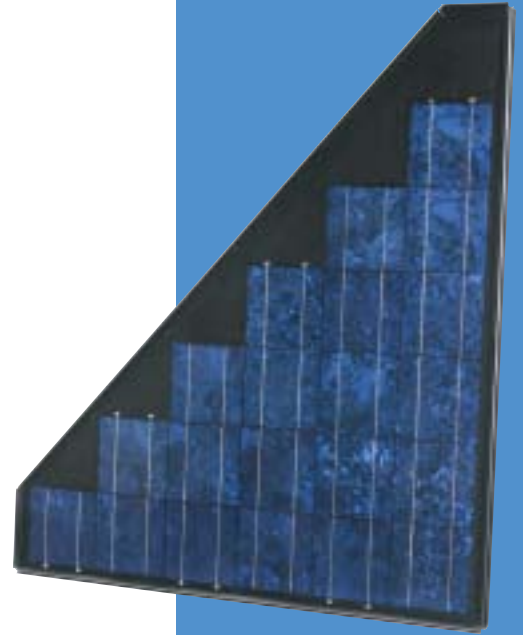

*The laminated glass module is glazed into a high torsion black anodized aluminum frame.*



*Sharp's triangular modules with black frames, trim strips, and backing sheets allow for the seamless integration of the system into the home's design.*

## FEATURES

- Left and right triangular modules offer greater design flexibility and greater integration for roofline aesthetics
- High-power module (70W) using 21 square multi-crystal silicon solar cells with 13.44% cell conversion efficiency
- Photovoltaic module with bypass diode minimizes the power drop caused by shade
- Black anodized aluminum frame and "L" hook design located along frame perimeter for easy integration with residential system mounting hardware
- Water white, tempered glass, EVA laminate, and a weather-proof film yield long-life modules while enhancing cell performance
- Nominal 7 VDC output is ideal for residential system applications
- Manufactured in ISO 9001 certified facilities
- 25-year limited warranty
- UL Listings: UL 1703, cUL

## ELECTRICAL CHARACTERISTICS

Cell	Multi-crystal silicon
No. of Cells and Connections	21 in series
Open Circuit Voltage (Voc)	12.43V
Maximum Power Voltage (Vpm)	9.98V
Short Circuit Current (Isc)	7.81A
Maximum Power Current (Ipm)	7.02A
Maximum Power (Pm)*	70W
Minimum Power (Pm)*	63W
Encapsulated Solar Cell Efficiency (ηc)	13.44%
PTC Rating (W)**	61.46
Maximum System Voltage	600VDC
Series Fuse Rating	15A
Type of Output Terminal	Lead Wire with MC Connector

## MECHANICAL CHARACTERISTICS

Dimensions (A x B x C below)	45.86 x 38.98 x 1.81" / 1165 x 990 x 46mm
Weight	26.9lbs / 12.2kg
Packing Configuration	2 pcs per carton
Size of Carton	46.14 x 43.5 x 5.0" / 1172 x 1105 x 127mm

## ABSOLUTE MAXIMUM RATINGS

Operating Temperature	-40 to 194°F / -40 to +90°C
Storage Temperature	-40 to 194°F / -40 to +90°C
Dielectric Isolation Voltage	2200 VDC max.

## IV CURVES

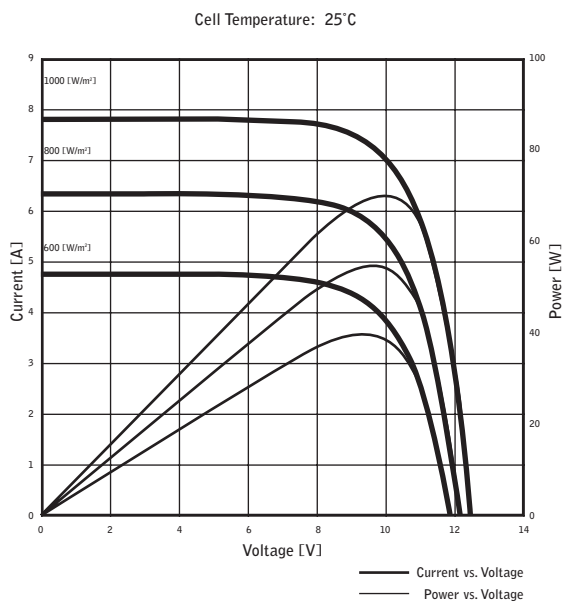

Current, Power vs. Voltage Characteristics

## DIMENSIONS

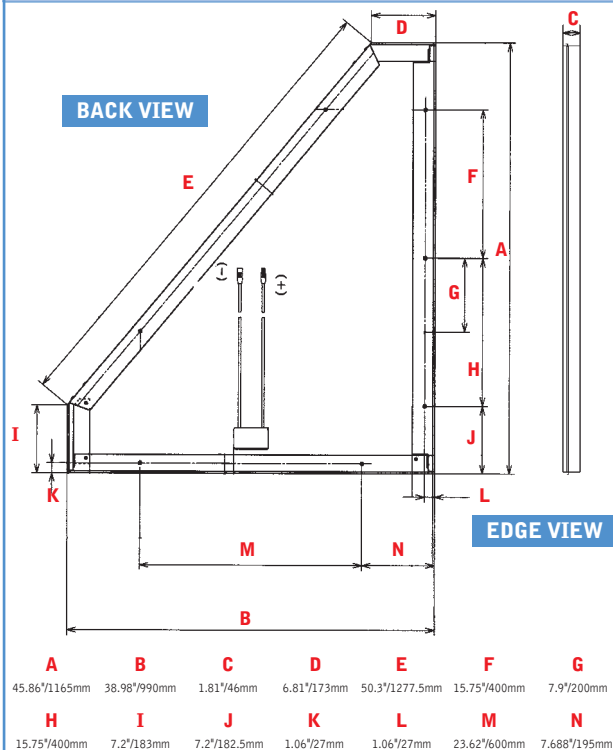

Specifications are subject to change without notice.

\* (STC) Standard Test Conditions: 25°C, 1 kW/m<sup>2</sup>, AM 1.5

\*\* (PTC) Pacific Test Conditions: 20°C, 1 kW/m<sup>2</sup>, AM 1.5, 1 m/s wind speed

In the absence of confirmation by product manuals, Sharp takes no responsibility for any defects that may occur in equipment using any Sharp devices.  
Contact Sharp to obtain the latest product manuals before using any Sharp device.

